



Brighton Series Telescoping Patio Door



6-12-2020

Brighton Telescoping Patio Door Features

- Stacking and pocket configurations
 - * Stacking telescoping door systems stack all panels in line with the stationary panel, thus all panels are always visible in the stacking configuration
 - * Pocketed telescoping door systems incorporate a pocket in the wall cavity, thus all panels would be visible when the door is fully-closed, and all panels would be hidden in the wall pocket when the door is fully-open
- One panel (pocket only) to eight panel configurations with maximum overall frame width of 20'0"
- Door jamb depth will vary depending on the number of panels in your chosen layout
- Pine wood interior. Extruded aluminum exterior.
- French (wide rail) or Narrow Rail panel styles
- Main frame head and sill use dark bronze anodized aluminum extrusions
- Folding aluminum nailing fins
- Heavy-duty interlock improves air and structural performance
- Panels slide on two tandem, heavy-duty, end-adjustable, ball bearing rollers for smooth operation
- 3/4" insulated glass with Low-E. Tempered for safety.
- Two-point locking gear and keeper
- Flush-mounted handles with keyed lock
- Brushed nickel finger pull located at the edge of the lead operating panel

Specifications

Panel Thickness	1 3/4"
Maximum Panel Width	4-0 (47 3/4" actual size)
Maximum Panel Height	French: 10-0 (116 1/2" actual size) Narrow: 8-0 (92 1/2" actual size)
Maximum Number of Panels	8
Maximum Frame Width	20'
Maximum Frame Height	10-0 (119 1/8" actual size)

Pocket Door Configurations

P=POCKET
A=ACTIVE PANEL

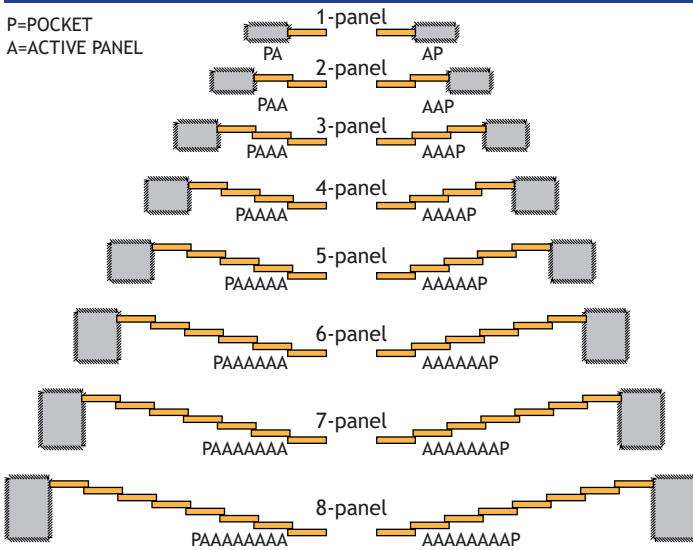

Stacking Door Configurations

F=FIXED PANEL
A=ACTIVE PANEL

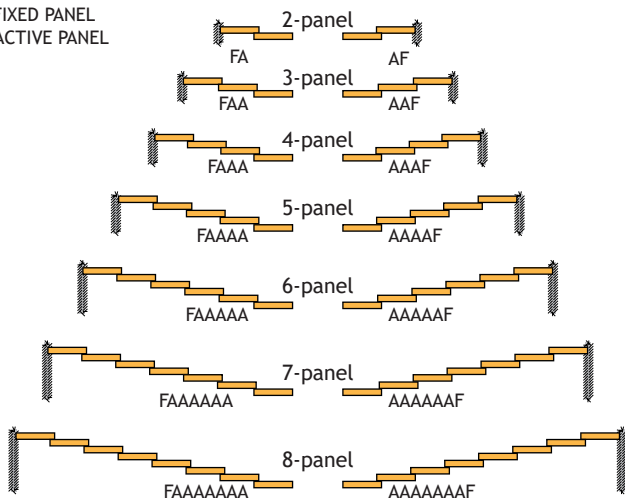

Glass Options

- Tinted glass
- Obscure (privacy) glass
- Laminated (safety and sound attenuation) glass

Interior Options

- Pre-finished white, black or custom color
- Primed interior

Exterior Options

- More than 30 "Quick Pick" colors
- AAMA 2604 powder coat finish is standard with an upgrade to AAMA 2605 powder coat optional custom powder coat colors

Hardware Options

- Finishes available: Oil Rubbed Bronze, Brushed Nickel, White and Black (*shown*)

Muntin Options

- Flat muntin between between the glass
 - 5/8" , 3/4" or 1" wide
- Contoured muntin between the glass
 - 3/4" wide
- Simulated Divided Lite (SDL)
 - Beveled 7/8", 1 1/4" or 2" wide
 - Pyramid 7/8" wide
- Flat two tone muntin between the glass
 - 5/8" or 3/4" wide
- Contoured two tone muntin between the glass
 - 3/4" wide
- Standard and custom muntin patterns and configurations available

Sill

- Full sill with exterior sill nose and interior riser



See more at
www.QuakerWindows.com

