



**Brighton  
R-50**

**5 15/16" Frame Depth  
Sliding Door (French Rail)**

## BRIGHTON SERIES SLIDING DOOR (FRENCH RAIL)

The Quaker Brighton Series French Rail Sliding door is ideal for a variety of applications including - Energy Efficient, Apartments and Assisted Living.

### FEATURES

- ◇ Commercial Framing System
  - 5 15/16' main frame (4 9/16" fin to interior)
- ◇ Enhanced Design
  - Solid extruded aluminum clad exterior framing: 0.078" metal thickness
  - Radiata pine interior
  - 8 9/16" bottom stile on panels
  - Extended drip cap for water infiltration protection
  - Fiberglass sill
  - Dual-seal frame weather-strip at panel face and edge
  - Nailing fin
- ◇ Glazing
  - 3/4" insulated glass
  - Low-E with argon gas
- ◇ Hardware
  - Heavy-duty ball-bearing rollers make operation easy and smooth
  - Truth Signature Hardware with safe locking system
- ◇ Screen
  - Extruded aluminum screen frame with BetterVue™ mesh

### BENEFITS

- ◇ The capacity to match exterior colors for unique project facades
- ◇ The capacity to match interior colors for unique decor
- ◇ The ability to facilitate custom sizes for taller and wider door openings

### PERFORMANCE

- ◇ Structural & Thermal (test reports or thermal simulations available upon request)

Model	Brighton French Rail Sliding Door
	Active-Fixed
AAMA/WDMA/CSA 101/I.S.2/A440-08 Rating	R-50
Structural Load P.S.F.	
Air at 50 MPH (cfm/ft <sup>2</sup> )	
Water (No Penetration) P.S.F.	
U-Value (with EnergyMax Glass Package)	0.28
SHGC (with EnergyMax Glass Package)	0.17
Test size	

### OPTIONS

- ◇ Available Configurations
  - Fixed-Active
  - Active-Fixed
  - Fixed-Active-Active-Fixed
  - Sidelites
  - Transoms
- ◇ Muntin Choices
  - Internal, wood removable or simulated divided lites available
- ◇ Screen
  - Extruded aluminum screen frame with aluminum wire mesh
  - Extruded aluminum screen frame with sunscreen mesh
  - Extruded aluminum screen frame with stainless steel 0.009" thickness mesh
- ◇ Glazing
  - Capillary tubes
  - Wide variety of glazing, tinting and thickness options
- ◇ Panning & Trim Choices
  - Wide variety of trim available
- ◇ Mulling
  - Wide variety of structural mulls

Our products are tested to the standards of and certified by the American Architectural Manufacturer's Association, the National Fenestration Rating Council and the Window & Door Manufacturers Association.



## ARCHITECTURAL PAINT COATINGS AND FINISHES

◇ Baked on powder coat finish meets ANSA/AAMA 2604 specs and is available in unlimited colors

- 11 Popular Colors

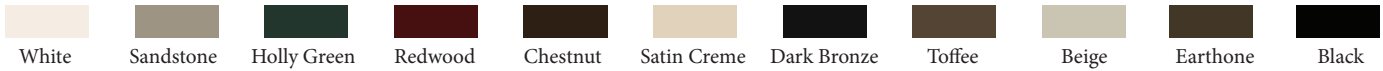

- 16 Impressive Colors

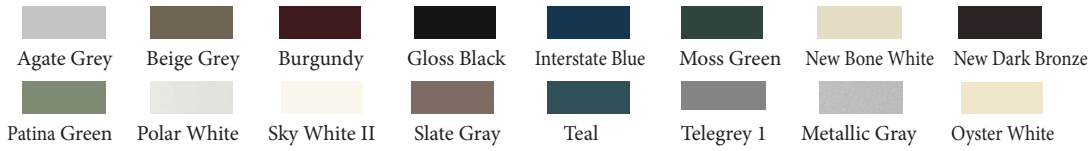

- 7 Resemble Colors (painted finish resembling anodized)



- Unlimited Custom Colors

◇ ANSA/AAMA 2605 powder coat finishes

◇ AAMA 611-98 Class I clear and tinted anodized finishes

\* Printed colors shown here may not accurately depict actual painted colors. Color samples are available upon request.

## INTERIOR FINISHES

◇ Interior painted finish is available in Natural Pine, Pre-Primed or Pre-Finished in white or any other colors



Our products are tested to the standards of and certified by the American Architectural Manufacturer's Association, the National Fenestration Rating Council and the Window & Door Manufacturers Association.





**QUAKER**  
COMMERCIAL WINDOWS AND DOORS



**Brighton**  
**R-50**

**5 15/16" Frame Depth**  
**Sliding Door (French Rail)**

**BRIGHTON SERIES SLIDING DOOR (2-PANEL FRENCH RAIL)**

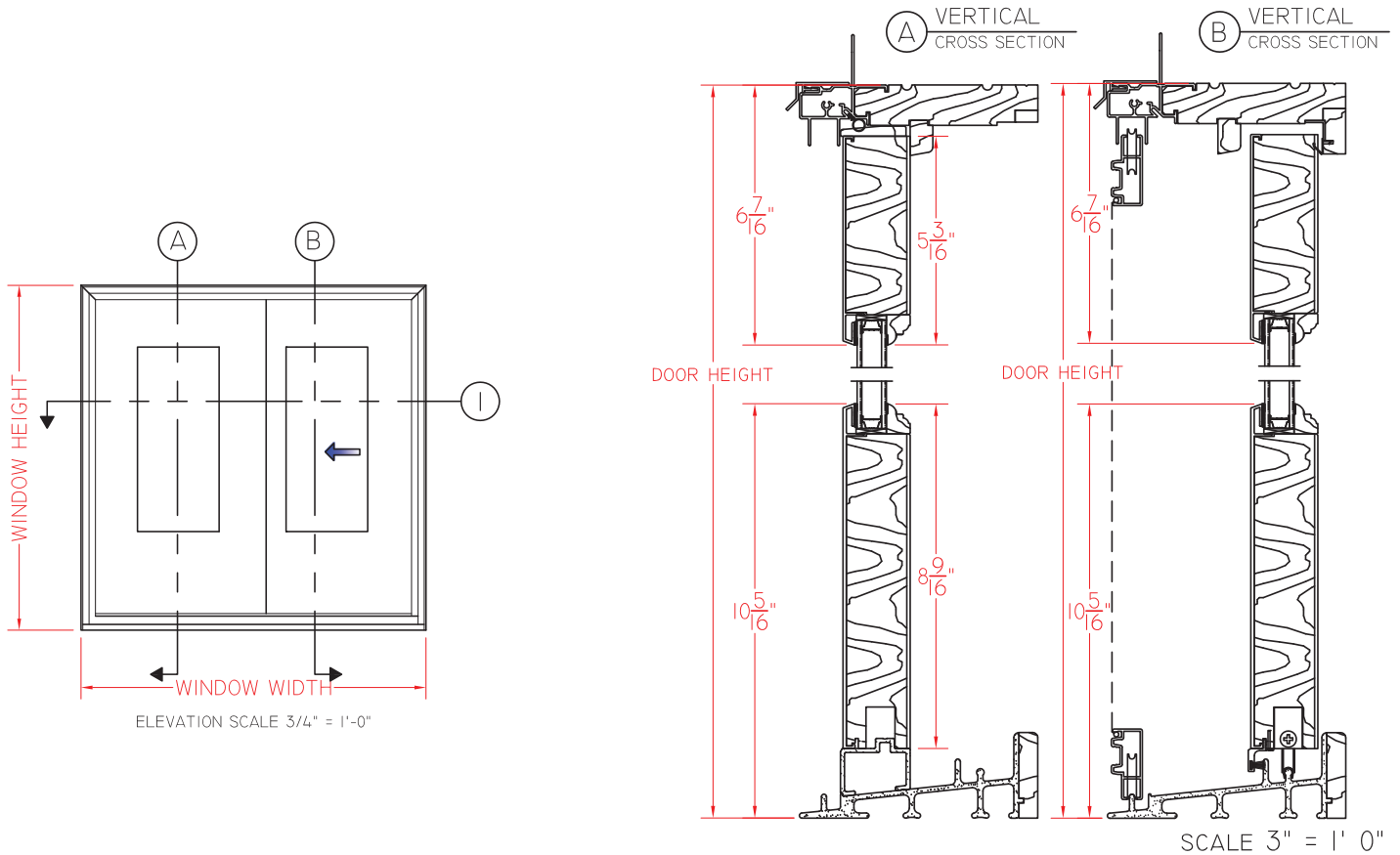
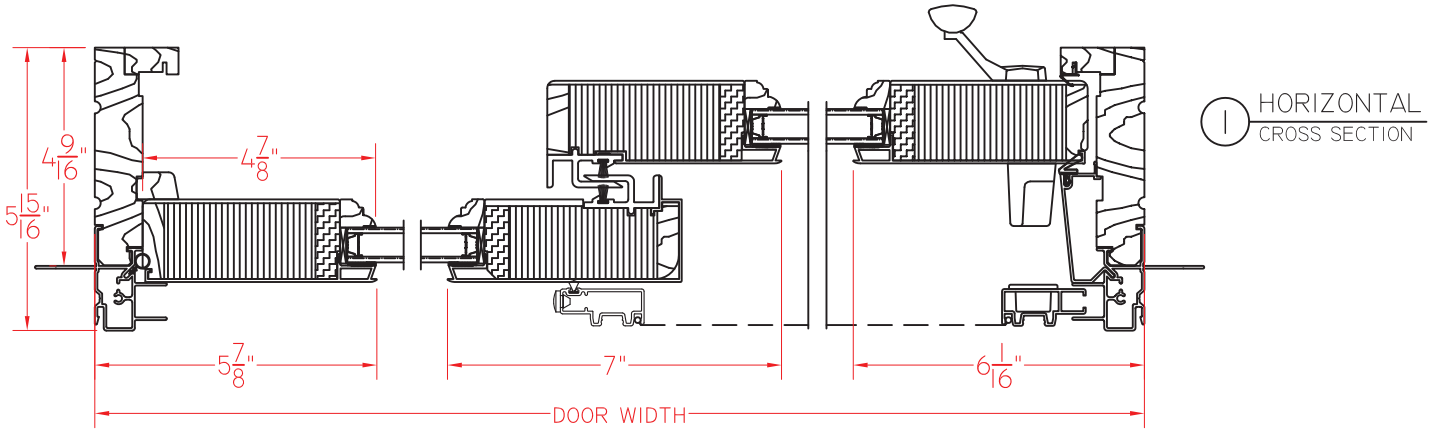

Our products are tested to the standards of and certified by the American Architectural Manufacturer's Association, the National Fenestration Rating Council and the Window & Door Manufacturers Association.



**QUAKER**  
COMMERCIAL WINDOWS AND DOORS

**BRIGHTON SERIES SLIDING DOOR (4-PANEL FRENCH RAIL)**

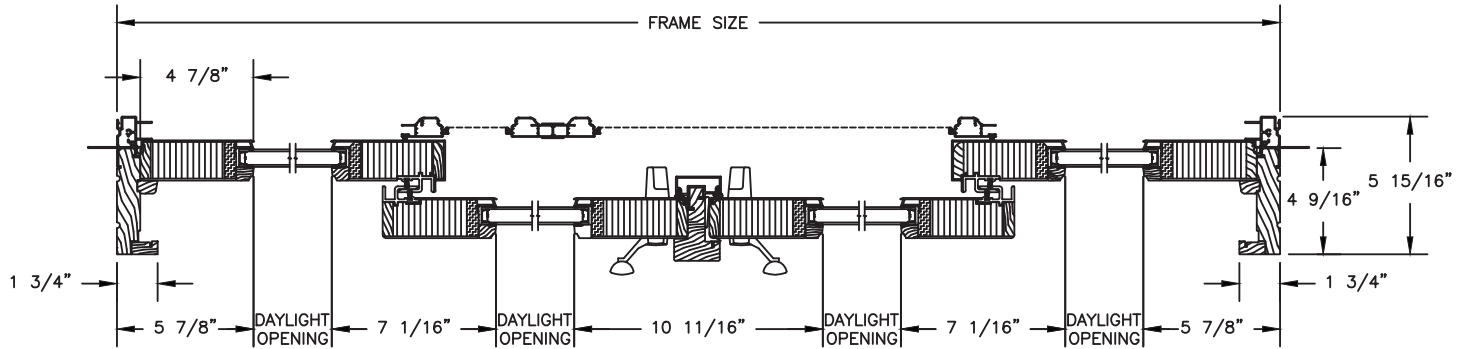

① HORIZONTAL CROSS SECTION

Ⓐ VERTICAL CROSS SECTION

Ⓑ VERTICAL CROSS SECTION

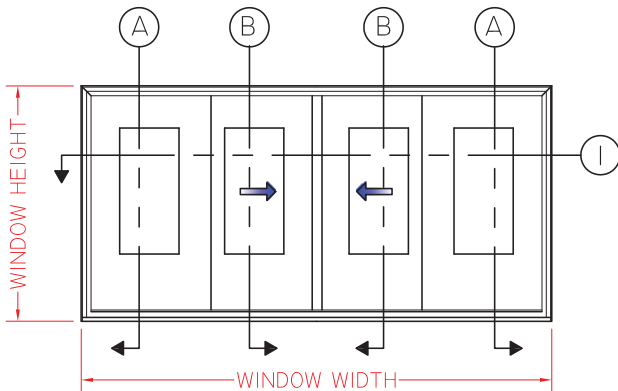
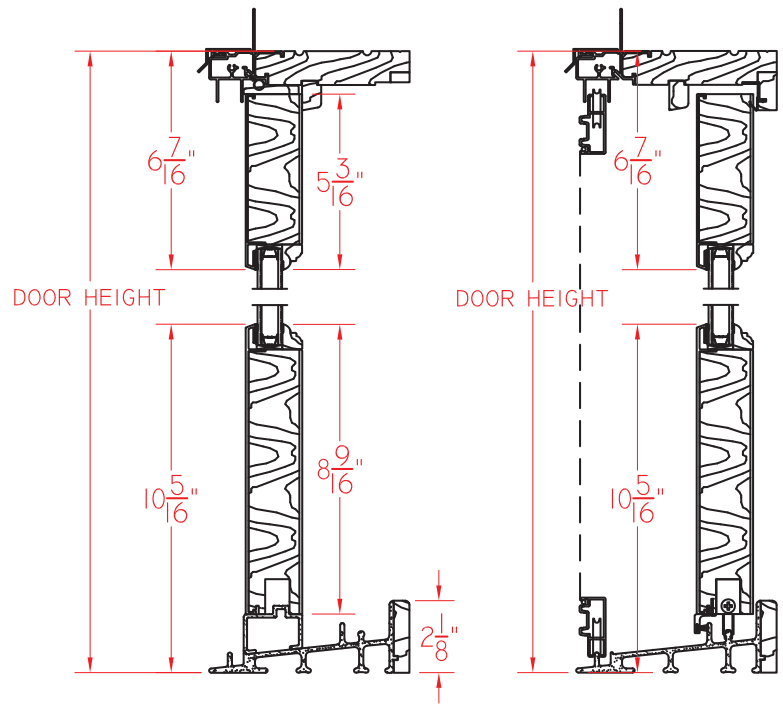

ELEVATION SCALE 1/2" = 1'-0"

SCALE 2" = 1' 0"

Our products are tested to the standards of and certified by the American Architectural Manufacturer's Association, the National Fenestration Rating Council and the Window & Door Manufacturers Association.





**QUAKER**  
COMMERCIAL WINDOWS AND DOORS



**Brighton  
R-50**

**5 15/16" Frame Depth  
Sliding Door (French Rail)**

**BRIGHTON SERIES SLIDING DOOR (SIDELITE FRENCH RAIL)**

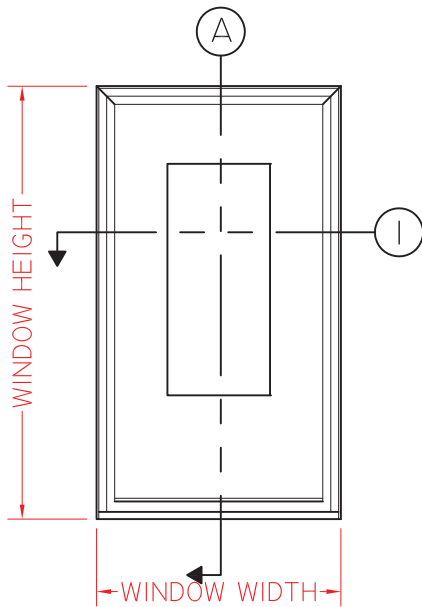
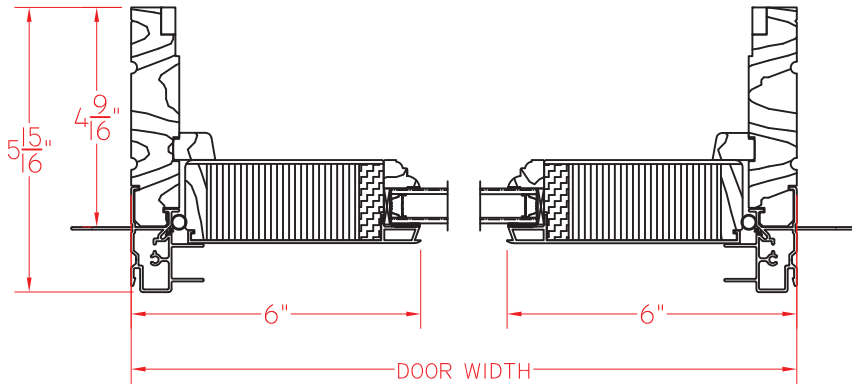

ELEVATION SCALE 3/4" = 1'-0"

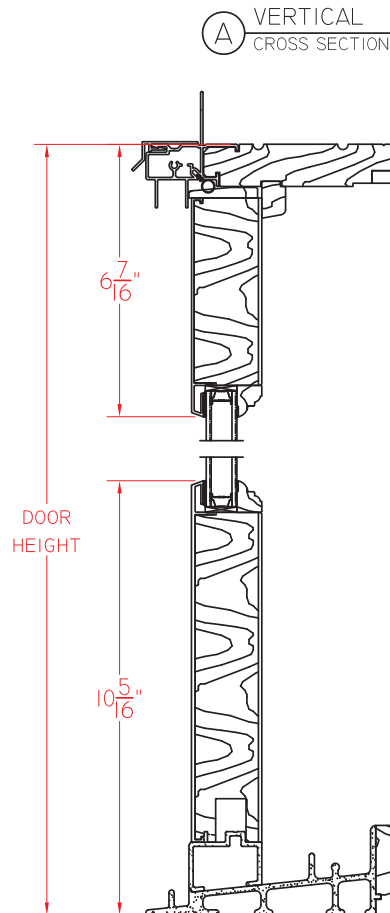

SCALE 3" = 1' 0"

Our products are tested to the standards of and certified by the American Architectural Manufacturer's Association, the National Fenestration Rating Council and the Window & Door Manufacturers Association.



**QUAKER**  
COMMERCIAL WINDOWS AND DOORS